

# 设计指南: TIDA-01393

# 适用于 Xilinx® Zynq® UltraScale+™ MPSoC 应用的电源参考设计



## 说明

此参考设计是一款可配置电源解决方案，用于在各种用例中对整个 Xilinx® Zynq® UltraScale+ (ZU+) 系列 MPSoC 器件进行处理。TPS65086x PMIC 拥有各种版本，因而此设计能够为从具有双核 Arm® Cortex®-A53 应用处理器和双核 Arm Cortex-R5 实时处理器的基本 ZU2CG 器件到更高端的 ZU7EV、ZU19EG 和 ZU21DR 器件供电，这些器件可向 MPSoC 添加其他组件，例如图形处理单元、视频编解码器单元以及多达 16 个 16.3Gbps 收发器。此设计包括众多其他可与 TPS65086x 器件共同使用的组件，例如外部负载开关、前置稳压器和按钮电路。

## 资源

<a href="#">TIDA-01393</a>	设计文件夹
<a href="#">TPS650864</a>	产品文件夹
<a href="#">TPS650861</a>	产品文件夹
<a href="#">CSD87381P</a>	产品文件夹
<a href="#">TPS22920</a>	产品文件夹
<a href="#">LMR64010</a>	产品文件夹
<a href="#">TPS54308</a>	产品文件夹
<a href="#">SN74LVC1G175</a>	产品文件夹
<a href="#">SN74LVC1G17</a>	产品文件夹
<a href="#">SN74LVC1G14</a>	产品文件夹

## 特性

- 10 个可编程输出轨
  - 3 个降压转换器、3 个降压控制器、3 个 LDO、1 个适用于 DDR 存储器终端的 VTT LDO
- 5 个负载开关
  - 3 个 TPS65086x 器件内部负载开关、2 个 TPS22920 外部负载开关
- 宽输入电压范围 (5V 至 24V)
- 4 个 GPO
- 借助 6 个 CTL 引脚或 I<sup>2</sup>C 进行定序控制

## 应用

- 工厂自动化和控制
- 单板计算机
- 模块化计算机
- 工业机器人 CPU 板
- 机器视觉: 视觉计算机
- 可编程逻辑控制器 (PLC): CPU PLC 控制器
- 工业监控器
- 测试和测量



咨询我们的 E2E™ 专家

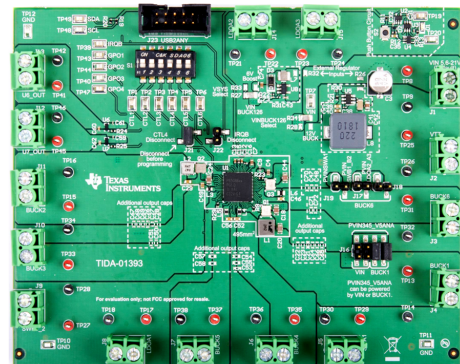
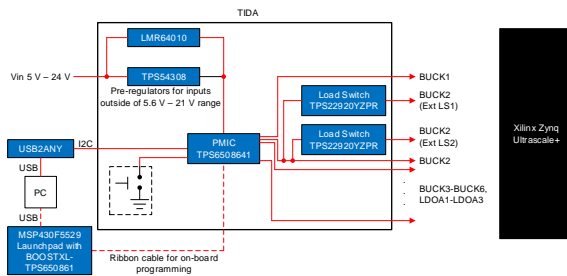



该 TI 参考设计末尾的重要声明表述了授权使用、知识产权问题和其他重要的免责声明和信息。

## 1 System Description

While this reference design is designed to handle the entire Xilinx® Zynq® UltraScale+ (ZU+) family of MPSoC devices across various use cases, the default configuration for this device uses the TPS6508641 PMIC device, and is targeted at powering the ZU3EG MPSoC. This design is by default made to follow the power map shown in [图 5](#), which offers full power domain flexibility. Many of the external components such as the output inductors chosen for this reference design are designed to be similar to the [Ultra96 Zynq UltraScale+ ZU3EG Development Board](#). Schematics for this design can be found [here](#). External components can be adjusted to fit different use cases, and the PMIC itself can even be swapped out with different variants of the TPS65086x PMIC device.

### 1.1 Key System Specifications

表 1. Key System Specifications

PARAMETER	SPECIFICATIONS	DETAILS
Input Power Source	DC 5 V to 24 V, depending on configuration	<a href="#">节 2.2.5</a>
BUCK1	5 V $\pm 5\%$	<a href="#">节 2.2.1</a>
BUCK2	0.85 V $\pm 5\%$	<a href="#">节 2.2.1</a>
BUCK3	1.1 V / 1.2 V $\pm 3\%$ , 3 A	<a href="#">节 2.2.1</a>
BUCK4	3.3 V $\pm 3\%$ , 3 A	<a href="#">节 2.2.1</a>
BUCK5	1.2 V $\pm 3\%$ , 3 A	<a href="#">节 2.2.1</a>
BUCK6	1.8 V $\pm 3\%$	<a href="#">节 2.2.1</a>
LDOA1	1.8 V $\pm 2\%$ , 200 mA	<a href="#">节 2.2.1</a>
LDOA2	1.2 V $-2\%$ $+3\%$ , 600 mA	<a href="#">节 2.2.1</a>
LDOA3	1.2 V $-2\%$ $+3\%$ , 600 mA	<a href="#">节 2.2.1</a>
VTT LDO	0.9 V $\pm 25$ mV, 1.8 A	<a href="#">节 2.2.1</a>
SWA1	3.3 V, 300 mA	<a href="#">节 2.2.1</a>
SWB1/SWB2, SWB1_2	1.8 V, 400 mA (800 mA, combined)	<a href="#">节 2.2.1</a>
U6_OUT	0.85 V $\pm 5\%$ , 4 A	<a href="#">节 2.2.4</a>
U7_OUT	0.85 V $\pm 5\%$ , 4 A	<a href="#">节 2.2.4</a>
Operating Ambient Temperature	$-40^{\circ}\text{C}$ to $+85^{\circ}\text{C}$	<a href="#">TPS650864 datasheet</a>
Solution Size	495mm <sup>2</sup>	<a href="#">图 14</a>

## 2 System Overview

### 2.1 Block Diagram

图 1. TIDA-01393 Block Diagram

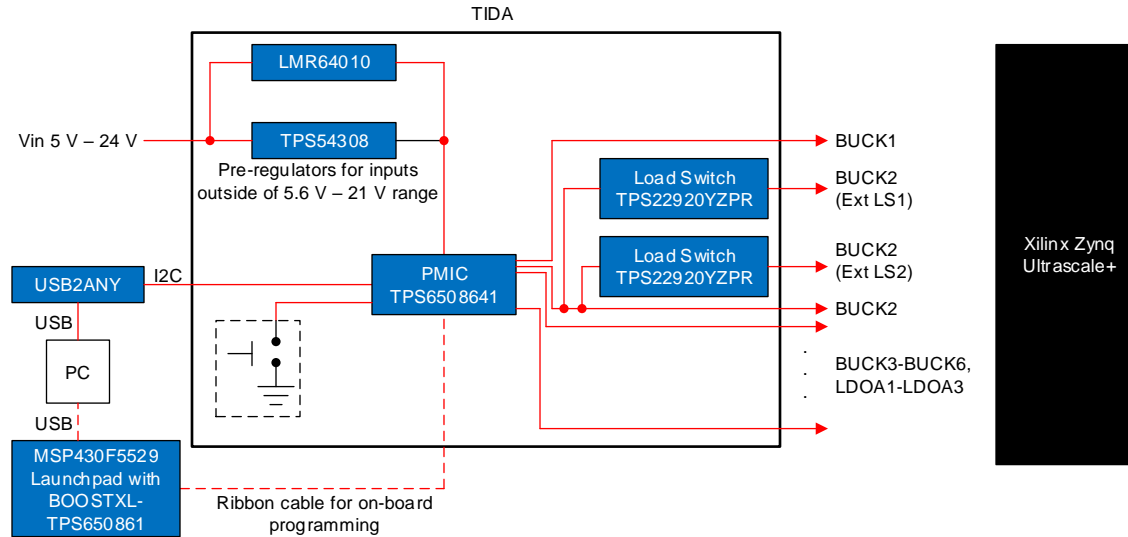

### 2.2 Design Considerations

This design has a lot of components that can be modified to fit different use cases. All of these components are broken down in this section.

#### 2.2.1 TPS650864 Variants

The TPS65086x PMIC device uses one-time-programmable (OTP) memory, which is programmed at the factory to specific settings depending on the requirements of the design. There are multiple pre-defined OTPs of the TPS65086x PMIC device under the TPS650864x family, which are designed for different uses cases and MPSoCs. 表 2 shows the voltage settings for all of the TPS650864x variants. The specific variant used for this design is the TPS6508641. The power maps for these various pre-defined variants are shown in 图 2 through 图 6. While most of these power maps are focused on the Xilinx® Zynq® UltraScale+ (ZU+) family of MPSoC devices, the flexibility of the TPS65086x PMIC device makes it a good option for other MPSoCs and FPGAs as well. Please see the [TPS650864 datasheet](#) for more information on these pre-defined OTPs.

表 2. TPS650864x Variants

PART NUMBER	APPLICATION	BUCK1	BUCK2	BUCK3	BUCK4	BUCK5	BUCK6	LDOA1	LDOA2	LDOA3	Power Map
TPS6508640	Xilinx Zynq UltraScale+ ZU6 - ZU15	3.3 V (25 mV)	0.85 V, 0.9 V (10 mV)	1.2 V (25 mV)	0.9 V (25 mV)	1.8 V (25 mV)	1.2 V, 1.35 V (10 mV)	2.5 V	1.5 V	1.2 V	图 2
TPS65086401	Xilinx Zynq UltraScale+ ZU2 - ZU5	1.8 V (25 mV)	0.85 V (10 mV)	0.85 V (25 mV)	3.3 V (25 mV)	3.3 V (25 mV)	1.5 V, 1.2 V, 1.1 V (10 mV)	1.8 V	1.2 V	1.2 V	图 3
TPS6508641	Xilinx Zynq UltraScale+ ZU2 - ZU5	Ext FB	0.85 V (10 mV)	1.1 V, 1.2 V (25 mV)	3.3 V (25 mV)	1.2 V (25 mV)	1.8 V (25 mV)	1.8 V	1.2 V	1.2 V	图 4
TPS65086470	Xilinx Artix 7	1 V (10 mV)	1.8 V (25 mV)	1.2 V (25 mV)	2.5 V (25 mV)	3.3 V (25 mV)	1.35 V, 1.5 V (25 mV)	1.8 V	0.7 V	0.7 V	图 6

图 2. TPS6508640 Power Map Example

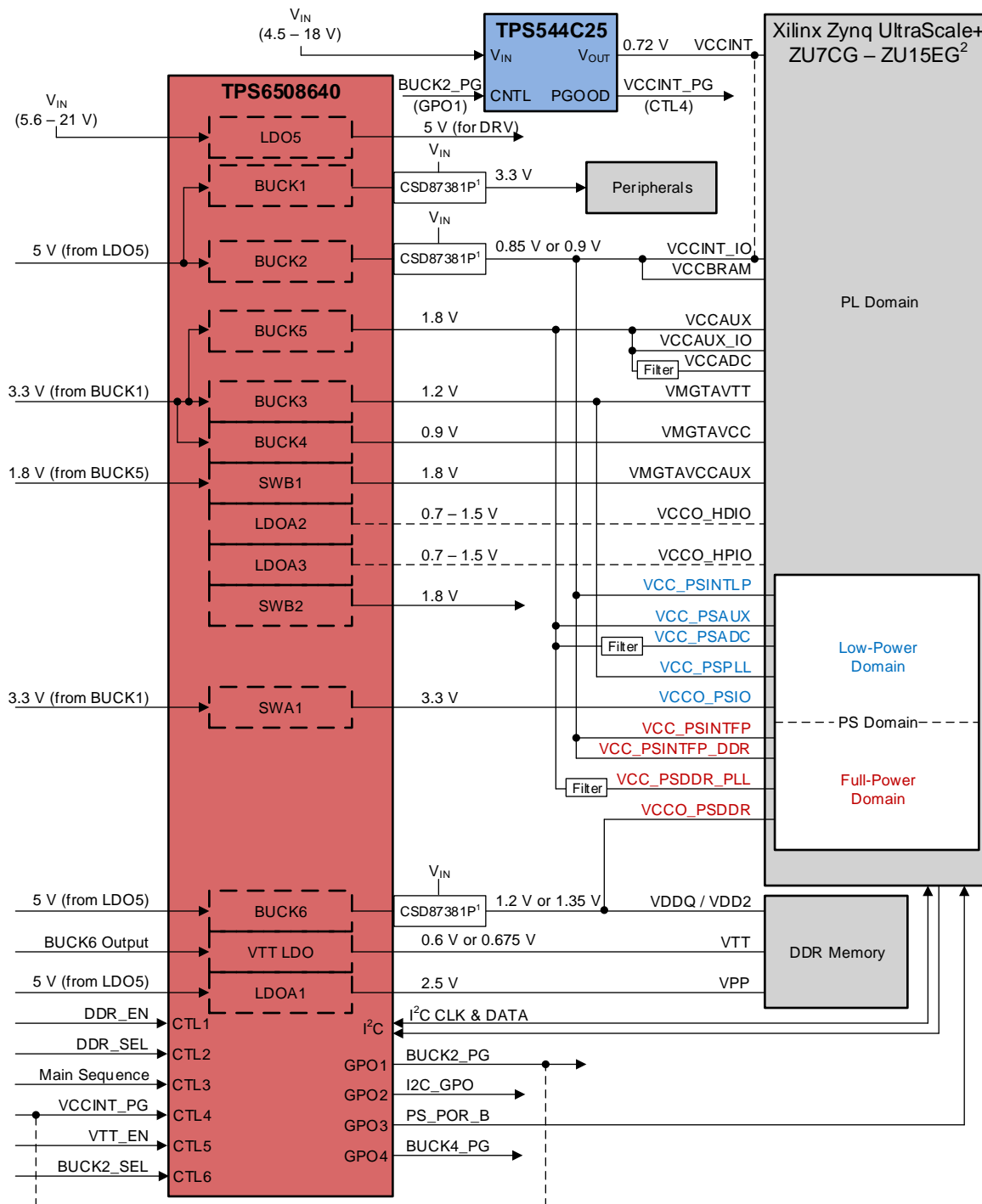

- (1) External FETs can be scaled to meet the current requirements of each design; CSD87381P is suitable up to approximately 15 A.
- (2) The TPS6508640 is not limited to the ZU7CG - ZU15EG. It can support other Ultrascale+ devices as long as the use case does not exceed the maximum specifications of the TPS6508640.

图 3. TPS65086401 Power Map Example

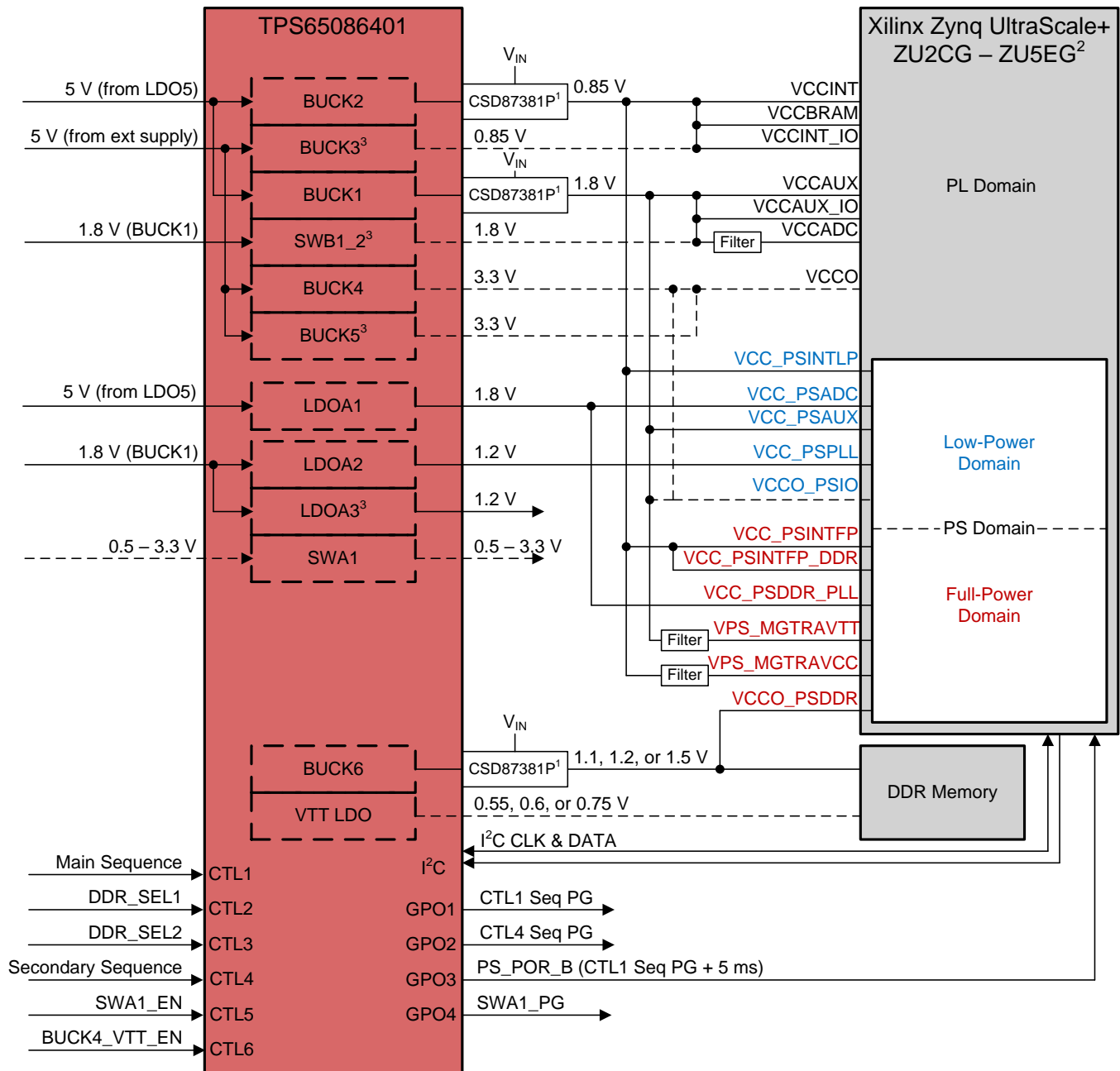

- (1) External FETs can be scaled to meet the current requirements of each design; CSD87381P is suitable up to approximately 15 A.
- (2) The TPS65086401 is not limited to the ZU2CG - ZU5EG. It can support other Ultrascale+ devices as long as the use case does not exceed the maximum specifications of the TPS65086401.
- (3) PL Domain can be optionally powered by BUCK3, SWB1\_2, BUCK5, and LDOA3 to allow it to be enabled and disabled by CTL4. This applies only to use cases where VCCINT current is less than 3 A.

图 4. TPS6508641 Always-On Power Map Example

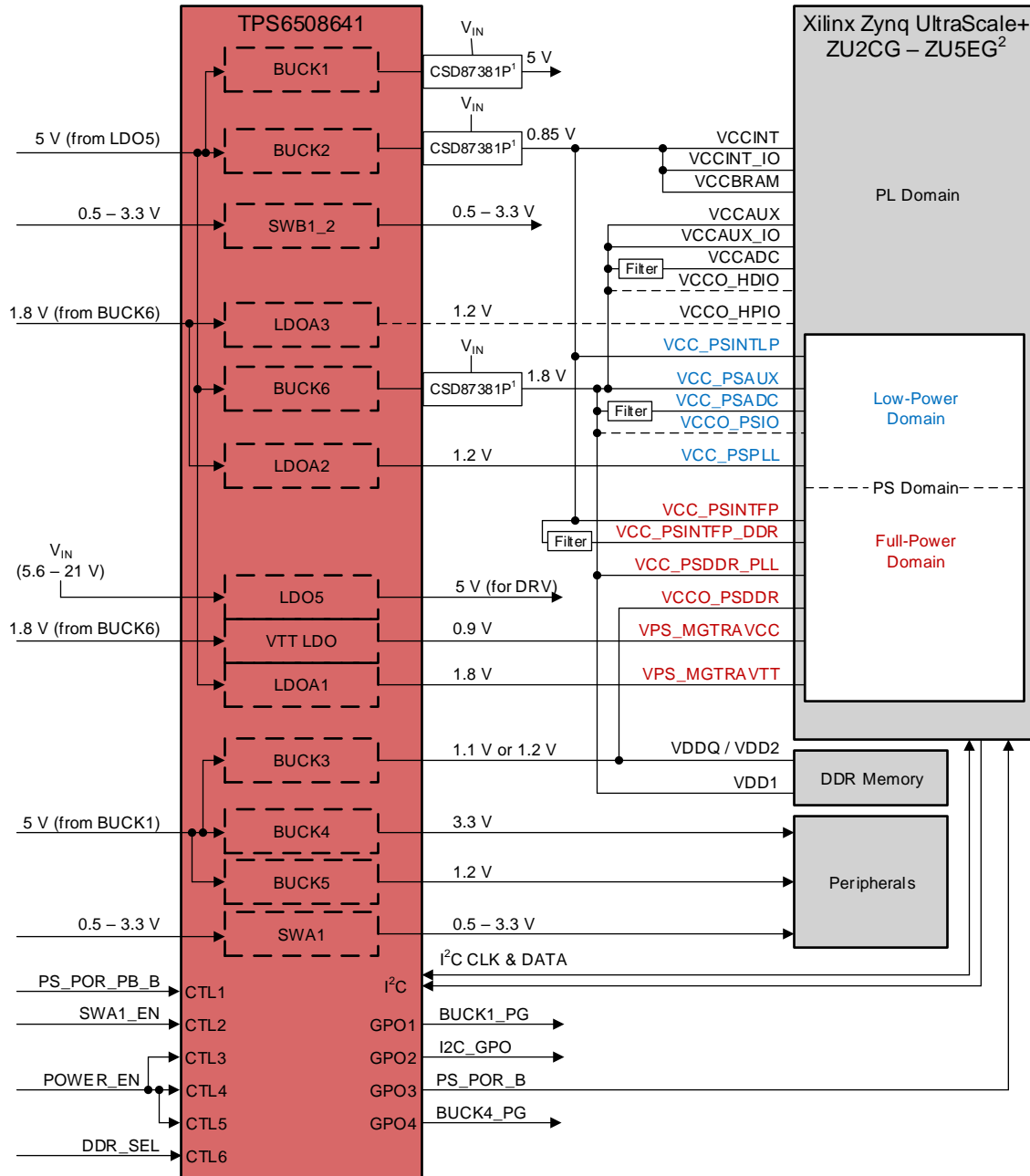

- (1) External FETs can be scaled to meet the current requirements of each design; CSD87381P is suitable up to approximately 15 A.
- (2) The TPS6508641 is not limited to the ZU2CG - ZU5EG. It can support other Ultrascale+ devices as long as the use case does not exceed the maximum specifications of the TPS6508641.

图 5. TPS6508641 Full Power Domain Flexibility Power Map Example

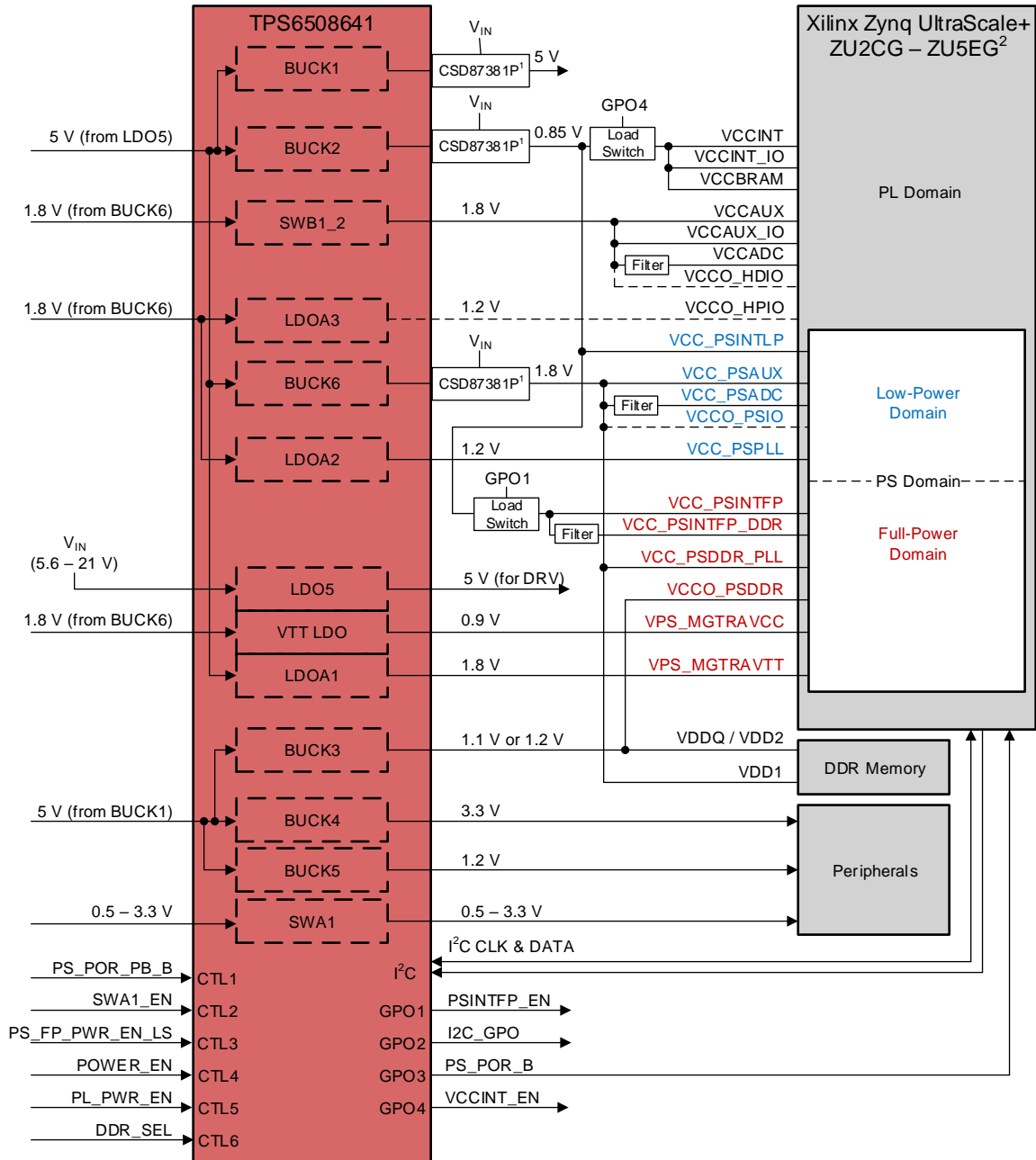

- (1) External FETs can be scaled to meet the current requirements of each design; CSD87381P is suitable up to approximately 15 A.
- (2) The TPS6508641 is not limited to the ZU2CG - ZU5EG. It can support other Ultrascale+ devices as long as the use case does not exceed the maximum specifications of the TPS6508641.

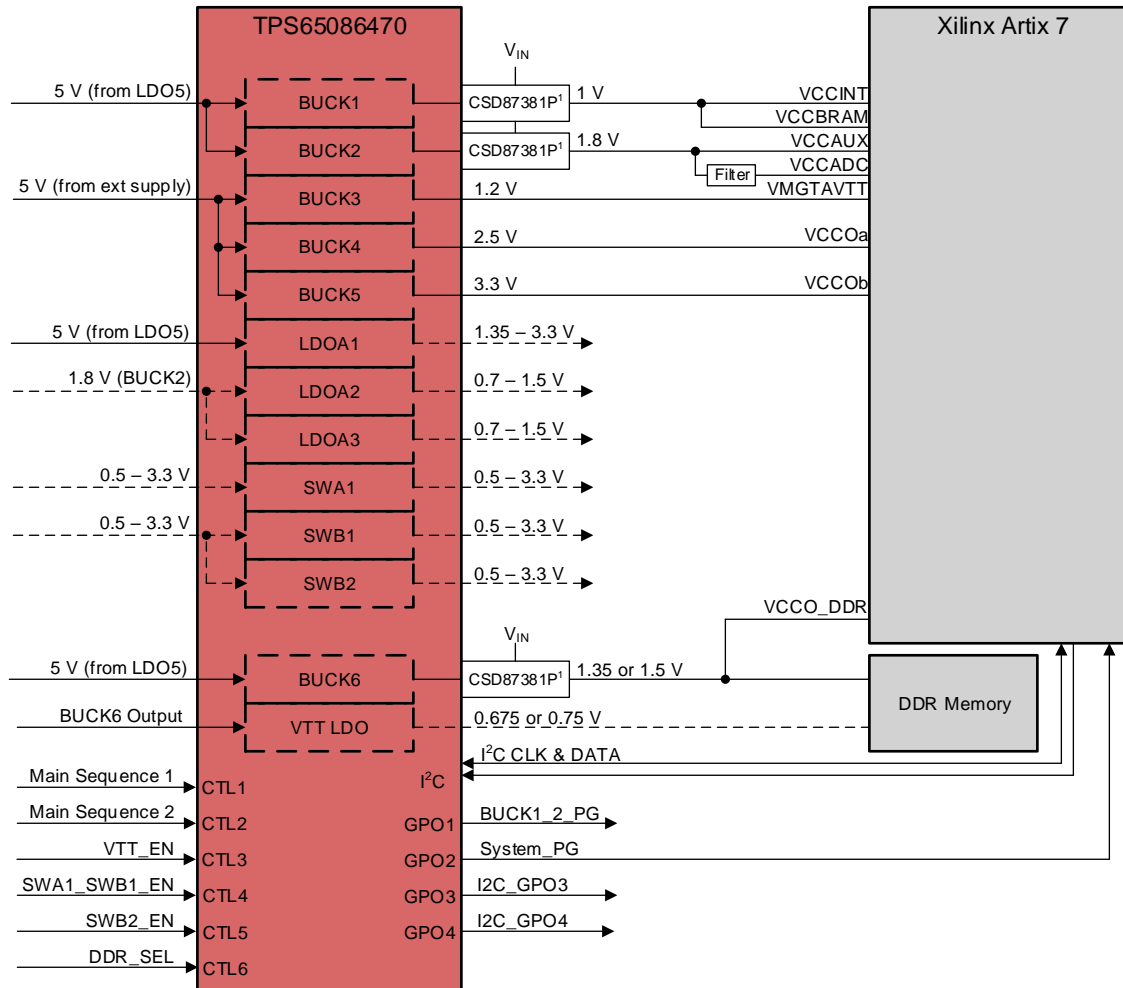
**图 6. TPS65086470 Power Map Example**

- (1) External FETs can be scaled to meet the current requirements of each design; CSD87381P is suitable up to approximately 15 A.

## 2.2.2 The User Programmable TPS65086100

For designs that require different OTP settings on the TPS65086x PMIC device than what is available in the pre-defined OTPs there are a few options. The first option is to get a new OTP defined that will be programmed in at the factory. The second option is to use one of the pre-defined OTPs, and change the settings as needed through I<sup>2</sup>C communication. The third option is to use the user-programmable version of the TPS65086x, the TPS65086100. This version of the TPS65086x PMIC device is designed to have the OTP memory programmed by the user to fit their specific design requirements. Please see the [TPS650861 datasheet](#), and [TPS65086100 Non-Volatile Memory Programming Guide](#) for more information on this device.



The two ways to program this device in a final production setting is either through a 3rd party programming vendor, or by programming on the end-product after PCB assembly. This design includes a ribbon cable connector, labeled J20 which can be used to connect this design to the BOOSTXL-TPS650861 BoosterPack programming board. Once soldered to the PCB the ribbon cable connector can be used for programming the TPS65086100, similar to how it could be programmed on the end-product after PCB assembly. It is recommended to first program the TPS65086100 in the programming board socket to confirm the settings are correct before soldering it to the PCB. Please refer to the [BOOSTXL-TPS650861 EVM User's Guide](#) for more information on this programming board.

The [OTP Generator](#) excel sheet is a tool used to generate all of the I<sup>2</sup>C commands that are needed for programming the TPS65086100, based on the settings that are chosen by the user. There are also pre-filled versions of the OTP Generator that have the settings filled in to match other OTP variants such as the [TPS6508641](#), [TPS6508640](#), and [TPS65086401](#). All of these pre-filled OTP Generators can be found in the technical documents of the [TPS650861 product folder](#) on TI.com. 表 3 shows which PMIC devices can be used to cover different Xilinx SoCs. While there are pre-defined variants for different SoCs, the user-programmable version of the TPS65086x PMIC device can be used across a very wide range of SoCs.

表 3. Xilinx Devices Powered by TPS65086x Family

Xilinx Family	Zynq-7000 Artix-7	Zynq-7000 Kintex	ZU+ MPSoC CG		ZU+ MPSoC EG			ZU+ MPSoC EV	ZU+ RFSocS <sup>(1)</sup>
	Device Names	XC7Z007S to XC7Z020	XC7Z030 to XC7Z100	ZU2CG to ZU5CG	ZU6CG to ZU9CG	ZU2EG to ZU5EG	ZU6EG to ZU15EG	ZU17EG to ZU19EG	ZU4EV to ZU7EV
TPS65086470	X								
TPS65086401/ TPS6508641			X		X				
TPS6508640				X		X			X
TPS650861	X	X	X	X	X	X	X	X	X

<sup>(1)</sup> For RFSocS above ZU21DR (ZU25DR, ZU27DR, ZU28DR, and ZU29DR), additional RF power regulators should be added. An example of this is to use [TPS7A8300](#) to power ADC\_AVCC, [TPS7A84](#) for DAC\_AVCC, and three [TPS62097s](#) for ADC\_AVCCAUX, DAC\_AVCCAUX, and DAC\_AVTT.

### 2.2.3 Controller Design Procedure

The TPS65086x PMIC device has 3 BUCK controllers with external FETs, allowing for the device to handle a wide range of load requirements. The external FETs can be chosen based on maximum load current so that the higher load requirements can be met, while reducing board area for the rails with lower load requirements. TI's [CSD85301Q2](#), [CSD87331Q3D](#), [CSD87381P](#), [CSD87588N](#), and [CSD87350Q5D](#) devices are recommended for the controllers, depending on the required maximum current. The default FETs used for this design are the [CSD87381P](#). In addition to the external FETs, the output inductors, output capacitors, and other passive components can all be adjusted based on the design requirements. Please refer to the [TPS650864 datasheet](#) for more information on how to choose the right components to fit specific design requirements.

## 2.2.4 External Load Switches

In some use cases, such as the one shown in 图 5 external load switches are required to allow for more flexibility in the power domain control. This is most common for battery powered applications, and other applications where independent control over the different power domains is required to achieve higher efficiency. This design uses two of the TPS22920 load switches to achieve this increased flexibility in the power domain. In this design the load switches are controlled using GPO1 and GPO4, and the load switch input is coming from the BUCK2 output. This is identical to the power map shown in 图 5.

## 2.2.5 Pre-Regulators (LMR64010 and TPS54308)

The input voltage range of the TPS65086x PMIC device is 5.6 V to 21 V. In some cases it may be desired to power the PMIC from a 5 V supply or a 24 V supply, which requires an additional pre-regulator to keep the PMIC input voltage within the 5.6 V to 21 V range. This section will go through the two regulators that are available in this design for pre-regulation of the input voltage.

### 2.2.5.1 Input Voltages <5.6 V (LMR64010)

The LMR64010 is used for input voltages that are below 5.6 V. This regulator is a boost converter that will boost the input voltage to 6 V so that it can be used to power the VSYS pin of the TPS65086x PMIC device. The input of this boost converter can be connected to the input of the board by populating R32 with a 0Ω resistor. The output of this boost converter can be connected to the VSYS pin by populating R33 with a 0Ω resistor.

### 2.2.5.2 Input Voltages >21 V (TPS54308)

The TPS54308 is used for input voltages that are above 21 V. This regulator is a buck converter that will bring the input voltage to 12 V so that it can be used to power the VSYS pin and the BUCK controller inputs of the TPS65086x PMIC device. The input of this buck converter can be connected to the input of the board by populating R26 with a 0Ω resistor. The output of this boost converter can be connected to the buck controller inputs and VSYS pin by populating R28 and R27 with a 0Ω resistor.

表 4. Resistors to Populate Based on Input Voltage

Vin	R26	R27	R28	R32	R33	R34
< 5.6 V				X	X	X
5.6 V - 21 V		X				X
> 21 V	X	X	X			

## 2.2.6 Push-Button Circuit

The push-button circuit included in this design is commonly used to turn on and shut down the outputs of the PMIC. This circuit can be used to turn on the PMIC outputs by setting the CTL1 pin high on a short key press, and turn off the PMIC outputs by setting the CTL1 pin low on a long key press. Please refer to the [Push-Button Circuit app note](#) for more information on how this circuit works.

## 2.3 Highlighted Products

### 2.3.1 TPS65086x

The TPS65086x is a highly versatile PMIC device that can provide system power for a wide variety of applications with 3 BUCK converters, 3 BUCK controllers, 3 general purpose LDOs, 3 load switches, and a VTT LDO for DDR memory termination. The BUCK controllers provide flexible power capable of up to 30A. External FETs can be made larger for high power designs, but can scale down in both size and cost for smaller designs. Voltage levels, sequencing, and other settings are defined in pre-programmed OTP memory, but can be modified using the I<sup>2</sup>C interface. The D-CAP2™ and DCS-Control high-frequency voltage regulators use small passives to achieve a small solution size. The D-CAP2 and DCS-Control topologies have excellent transient response performance, ideal for processor core and system memory rails that have fast load switching. The PMIC comes in an 8-mm × 8-mm, single-row VQFN package with thermal pad for good thermal dissipation.

图 7. TPS65086x Functional Block Diagram

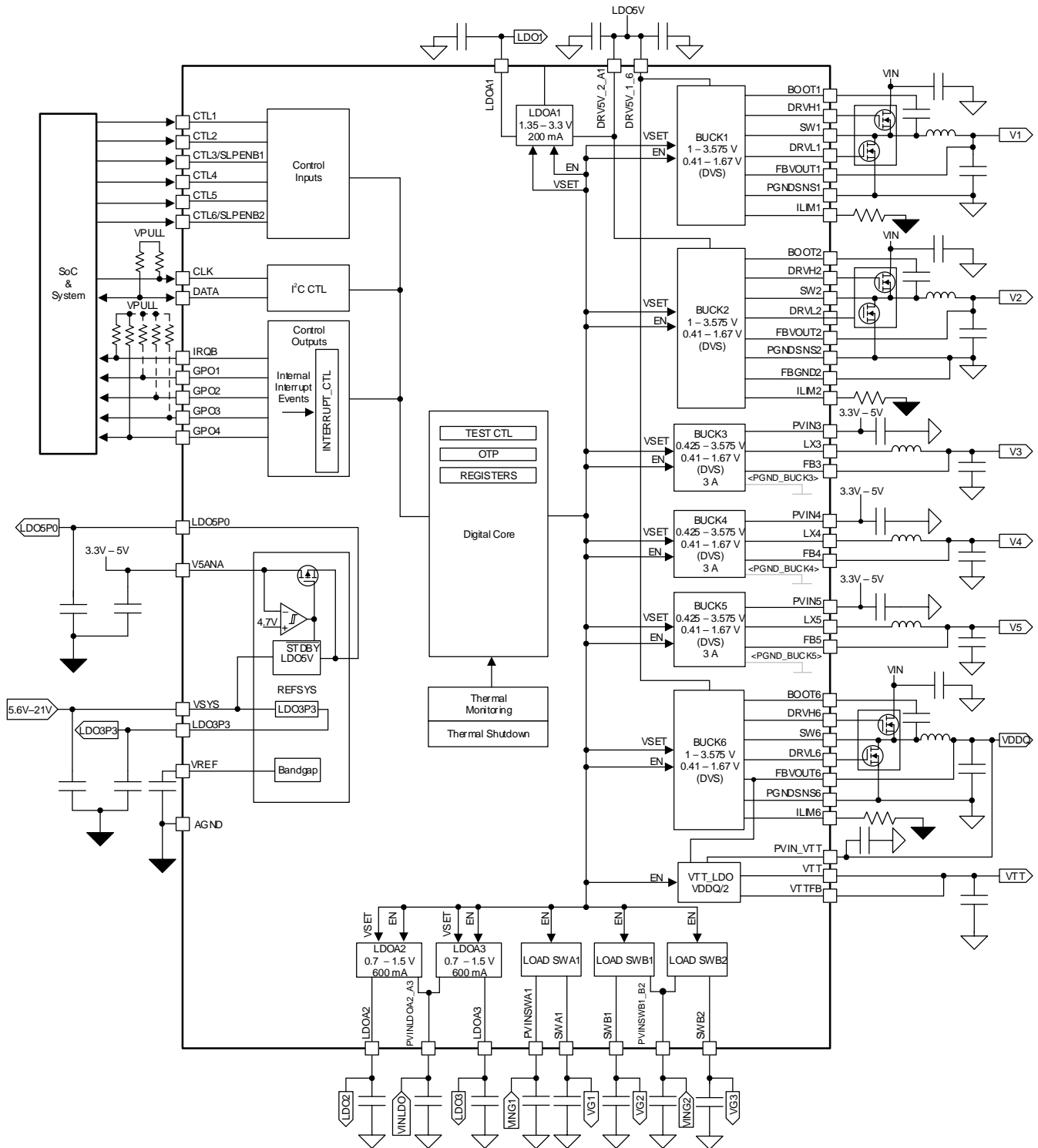

### 2.3.2 CSD87381P

The CSD87381P NexFET™ power block II is a highly optimized design for synchronous buck applications offering high current and high efficiency capability in a small 3 mm × 2.5 mm outline. Optimized for 5 V gate drive applications, this product offers an efficient and flexible solution capable of providing a high density power supply when paired with any 5 V gate driver from an external controller/driver. The CSD87381P is capable of supporting loads up to 15 A, but this device can be swapped out with other parts depending on if the load current is expected to be higher or lower.

图 8. CSD87381P Functional Block Diagram

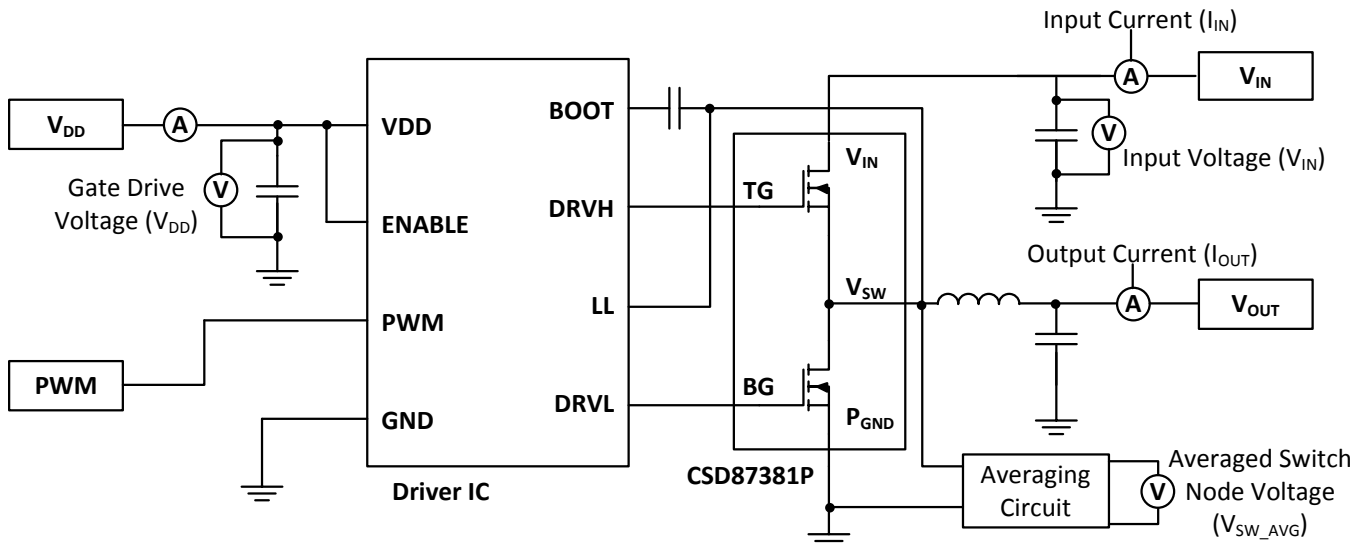

### 2.3.3 TPS22920

The TPS22920 is a small, space-saving load switch with controlled turn on to reduce inrush current. The device contains a N-channel MOSFET that can operate over an input voltage range of 0.75 V to 3.6 V and switch currents up to 4 A. An integrated charge pump biases the NMOS switch in order to achieve a minimum switch ON resistance. The switch is controlled by an on/off input (ON), which is capable of interfacing directly with low-voltage control signals. The TPS22920 has a 1250-Ω on-chip resistor for quick output discharge when the switch is turned off which insures that the output is not left floating. The TPS22920 has an internally controlled rise time in order to reduce inrush current. The TPS22920 is available in an ultra-small, space-saving 8-pin CSP package.

图 9. TPS22920 Functional Block Diagram

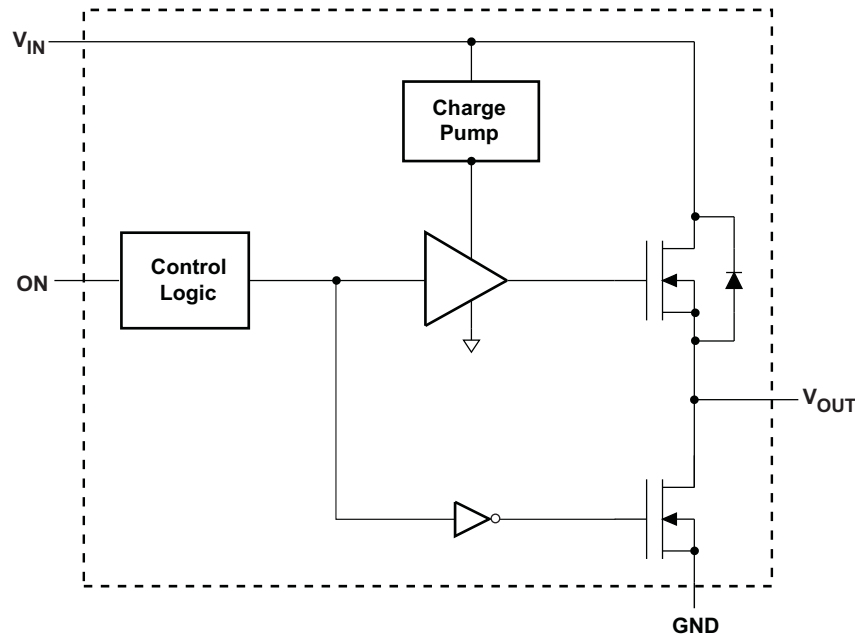

### 2.3.4 LMR64010

The LMR64010 switching regulator is a current-mode boost converter operating at a fixed frequency of 1.6 MHz. The use of SOT-23 package, made possible by the minimal power loss of the internal 1A switch, and use of small inductors and capacitors result in the industry's highest power density. The LMR64010 has a logic-level shutdown pin that can be used to reduce quiescent current and extend battery life. Protection is provided through cycle-by-cycle current limiting and thermal shutdown. Internal compensation simplifies design and reduces component count.

图 10. LMR64010 Functional Block Diagram

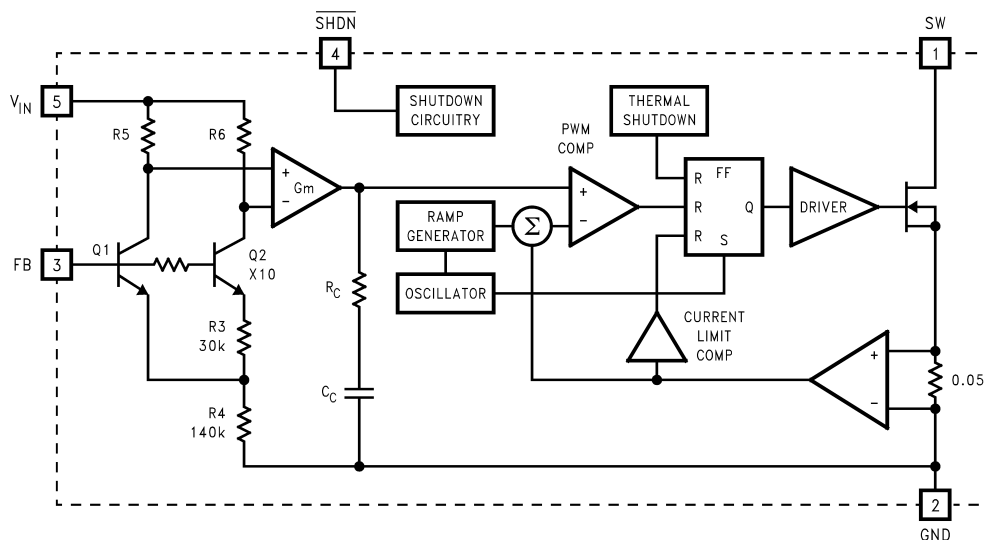

### 2.3.5 TPS54308

The TPS54308 is a 4.5-V to 28-V input voltage range, 3-A synchronous buck converter. The device includes two integrated switching FETs, internal loop compensation and 5-ms internal soft start to reduce component count. By integrating the MOSFETs and employing the SOT23 package, the TPS54308 achieves the high power density and offers a small footprint on the PCB. The TPS54308 operates in force continuous conduction mode (FCCM) during light load conditions, the switching frequency is maintained at an almost constant level over entire load range. Cycle-by-cycle current limit in both high-side MOSFET protects the converter in an overload condition and is enhanced by a low-side MOSFET freewheeling current limit which prevents current runaway. Hiccup mode protection is triggered if the over-current condition has persisted for longer than the present time.

图 11. TPS54308 Functional Block Diagram

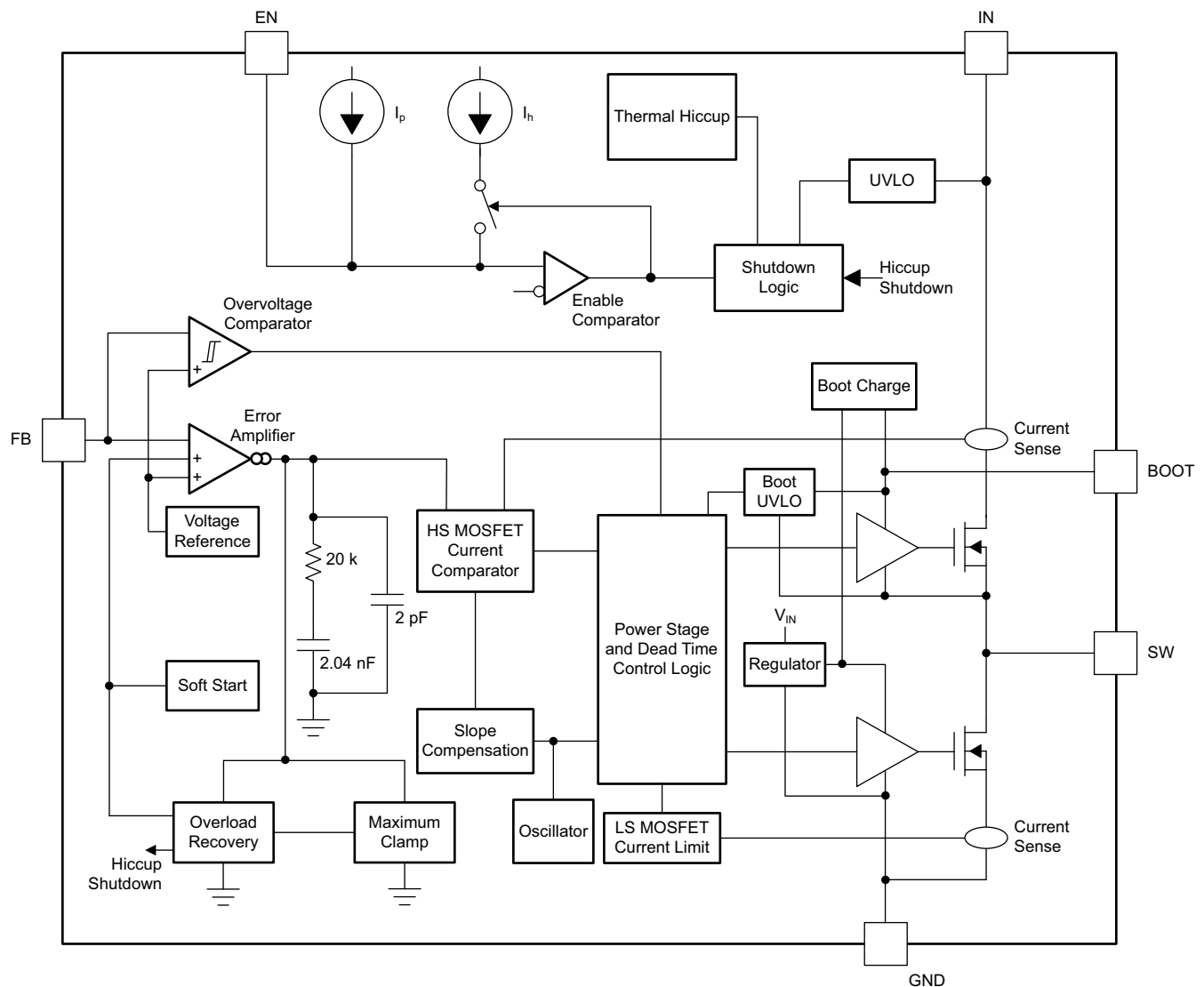

## 2.4 System Design Theory

PMICs allow for control of multiple power regulators with all sequencing and voltage level control built into one IC. The four types of regulators used in this PMIC are BUCK converters, BUCK controllers, LDOs and load switches. LDOs and load switches are very simple designs which do not require much explanation. Load switches use a FET to act as a switch connecting the input supply to the output while LDOs use a FET to dissipate power, adjusting the FET input voltage based to maintain a constant output.

The buck converter/controller uses a pair of FETs to switch the input voltage to an inductor between  $V_{in}$  and ground. In a BUCK controller the FETs are external to the IC, allowing for higher currents and better heat dissipation, while in a BUCK converter they are internal, allowing for smaller solution size. When the high side FET turns on, the input voltage is connected to the inductor, and when the low side FET turns on, the inductor is connected to ground. The difference between the input and output voltages is then forced across the inductor, causing current through the inductor to increase. During the ON time (high side FET on), the inductor current flows into both the load and the output capacitor, which charges the output capacitor. During the OFF time (low side FET on), the input voltage applied to the inductor is connected to ground. However, because the current in an inductor can not change instantly, the current through the inductor will slowly decrease. During this time, the output capacitor discharges into the load, maintaining a consistent load current. The total load current during the OFF time is the sum of the inductor and capacitor current. 图 13 demonstrates how a BUCK converter/controller functions. In this figure the low side FET is replaced with a diode, which can also be used to ground the inductor input during the OFF time.

图 12. BUCK Basic Function

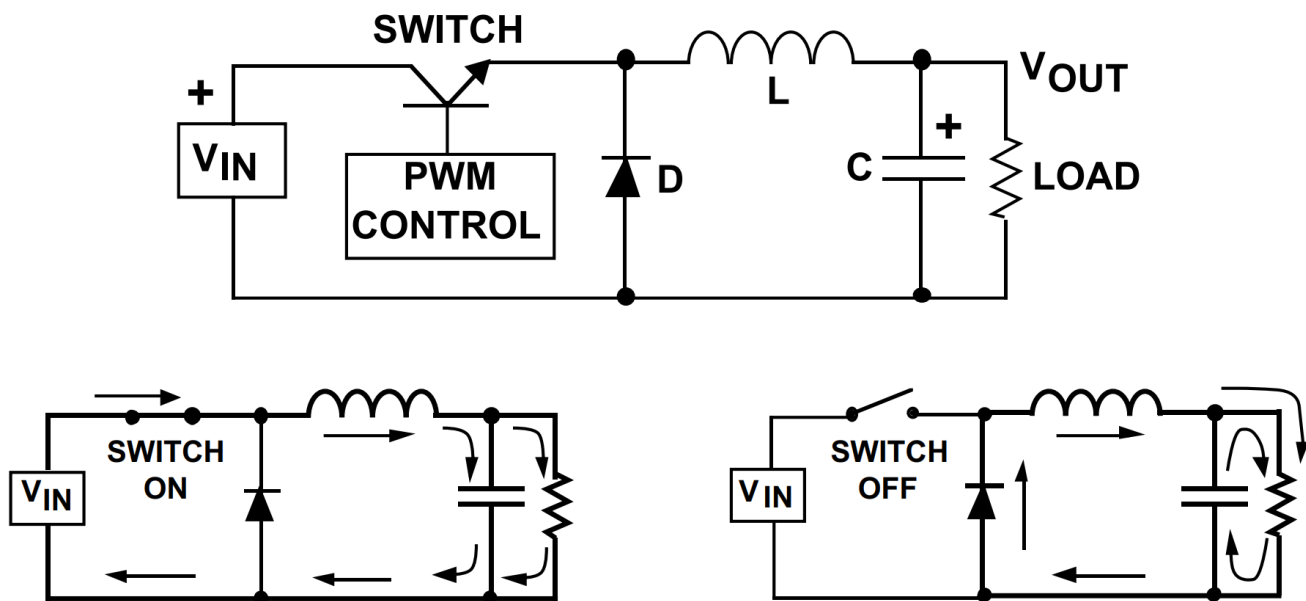



### 3 Hardware, Software, Testing Requirements, and Test Results

#### 3.1 Required Hardware and Software

##### 3.1.1 Hardware

The list below shows all of the hardware needed in order to power up the design and communicate with the PMIC. The power supply must be able to supply a minimum of 5 V and must be able to supply a current of at least 1 A. When loading the design a power supply capable of 10 A is recommended.

- PC with a USB port
- [USB2ANY Interface Adaptor](#)
- Power supply

The list below shows some of the optional hardware that is only needed if attempting to replace the TPS6508641 with the user-programmable TPS65086100.

- BOOSTXL-TPS650861 Programming BoosterPack
- MSP430F5529 USB LaunchPad Evaluation Kit

图 13 shows how to set up the hardware for this design.

图 13. Hardware Setup

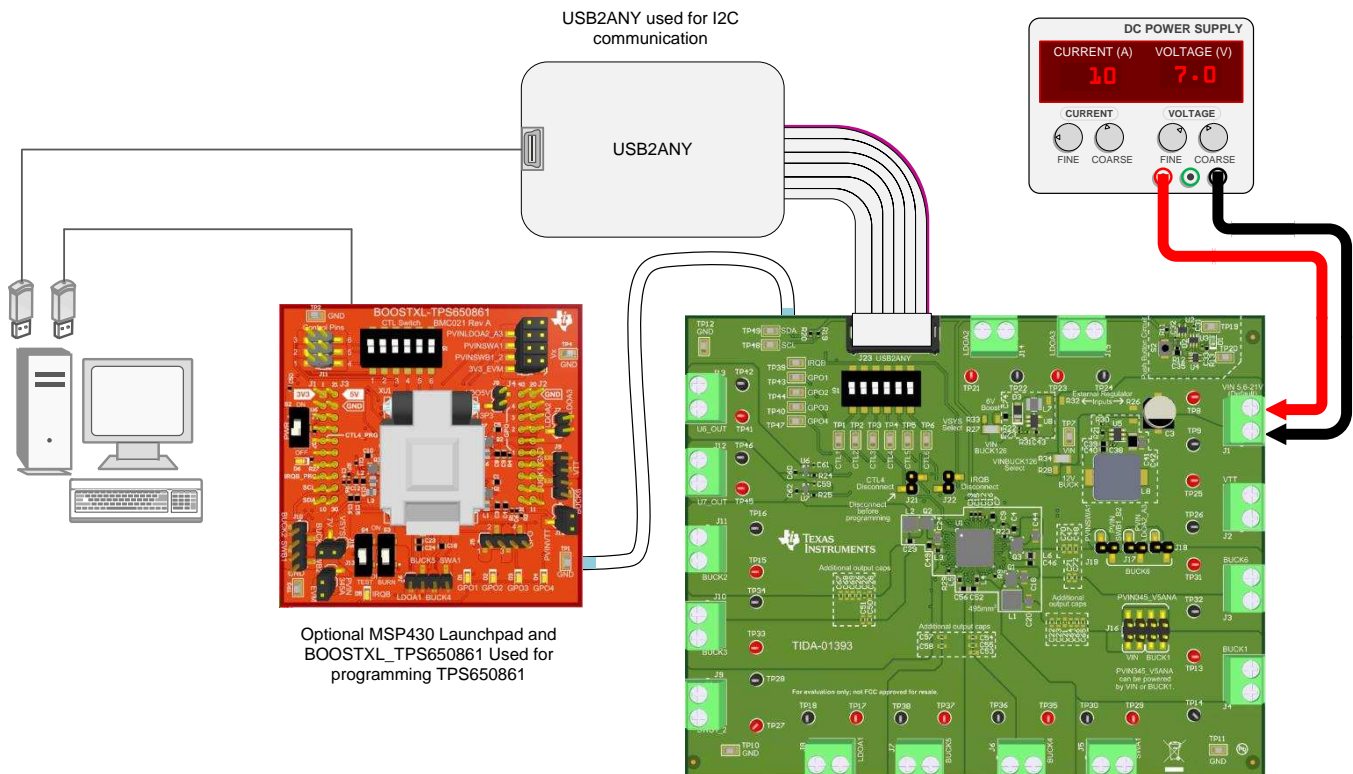

### 3.1.2 Software

The IPG-UI GUI is supplied to provide a simple way to communicate to the device via I<sup>2</sup>C communication. The GUI can be downloaded from <http://www.ti.com/tool/IPG-UI>. If the TPS65086100 is going to be used in the design, then an additional device file and script file will be required in order to program the device. The additional needed files can be downloaded [here](#). In order to use the BOOSTXL-TPS650861 programming BoosterPack a firmware update is required on the MSP430F5529 LaunchPad. The latest MSP430F5529 LaunchPad USB2ANY firmware (USB2ANY\_2.7.0.0\_LP.txt) can be downloaded [here](#), and the firmware update tool (MSP430\_USB\_Firmware\_Upgrade\_Example-1.3.1.1-Setup.exe) can be downloaded from [here](#).

### 3.2 Testing and Results

#### 3.2.1 Test Setup

图 14 shows how the board is set up for these test measurements. For ripple and transient measurements the output is measured across the output capacitor using a co-ax cable soldered to the pads. BUCKs 4 and 5 are excluded from most tests as the BUCK design is identical to BUCK3.

图 14. Board Test Setup

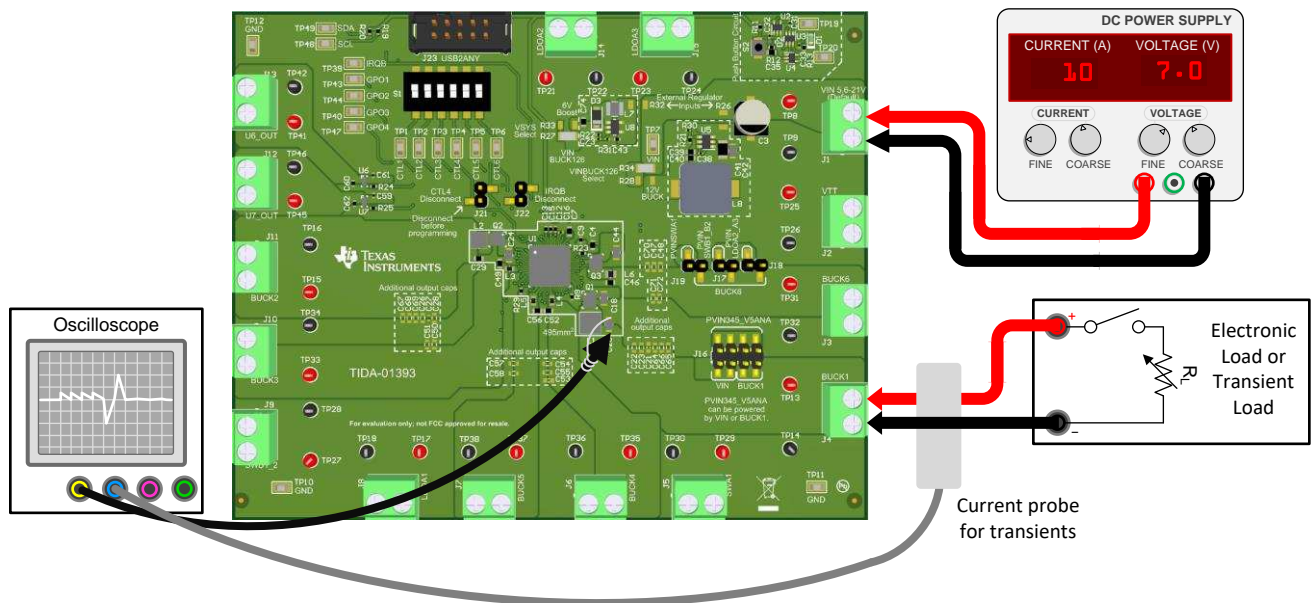

#### 3.2.2 Test Results

##### 3.2.2.1 Voltage Ripple

Voltage ripple measurements are taken at no load and 1 A loads to show the difference in ripple between pulse frequency modulation (PFM) mode at low loads and pulse width modulation (PWM) mode at higher loads. All measurements are taken at the default outputs for the TPS6508641 with a 12 V input.



表 5. Summary of Ripple Test Results

Regulator	Input Voltage	Output Voltage	Load	Inductance	Capacitance	Ripple
BUCK1	12 V	5 V	1 A	2.2 $\mu$ H (PN: 74438356022)	22 $\mu$ F (PN: GRM21BR61E226ME44L) + 2 x 47 $\mu$ F (PN: GRM21BR61A476ME15L)	35.5 mV
BUCK2	12 V	0.85 V	1 A	470 nH (PN: 744383360047)	22 $\mu$ F (PN: GRM187R61A226ME15D) + 2 x 47 $\mu$ F (PN: GRM21BR61A476ME15L)	19.1 mV
BUCK3	12 V	1.2 V	1 A	470 nH (PN: 74479262147)	22 $\mu$ F (PN: GRM187R61A226ME15D)	8.58 mV
BUCK6	12 V	1.8 V	1 A	1 $\mu$ H (PN: 74479275210)	22 $\mu$ F (PN: GRM187R61A226ME15D) + 2 x 47 $\mu$ F (PN: GRM21BR61A476ME15L)	12.9 mV

### 3.2.2.2 Transients

Transients are done at load steps that would be expected based on the power map shown in 图 5 for the ZU3EG MPSoC. Some of the ZU3EG power rails are not expected to have large transients or are not sensitive power rails, so the TPS6508641 regulators that would map to those power rails are not included in the transient tests. These power rails include LDOA2 (VCC\_PSPLL), LDOA3 (VCCO\_HP), BUCK4 (VCC\_3V3), BUCK1 (VCC\_5V0), and BUCK5 (VCC\_1V2). All transients are with a rise time of about 10 A/ $\mu$ s.

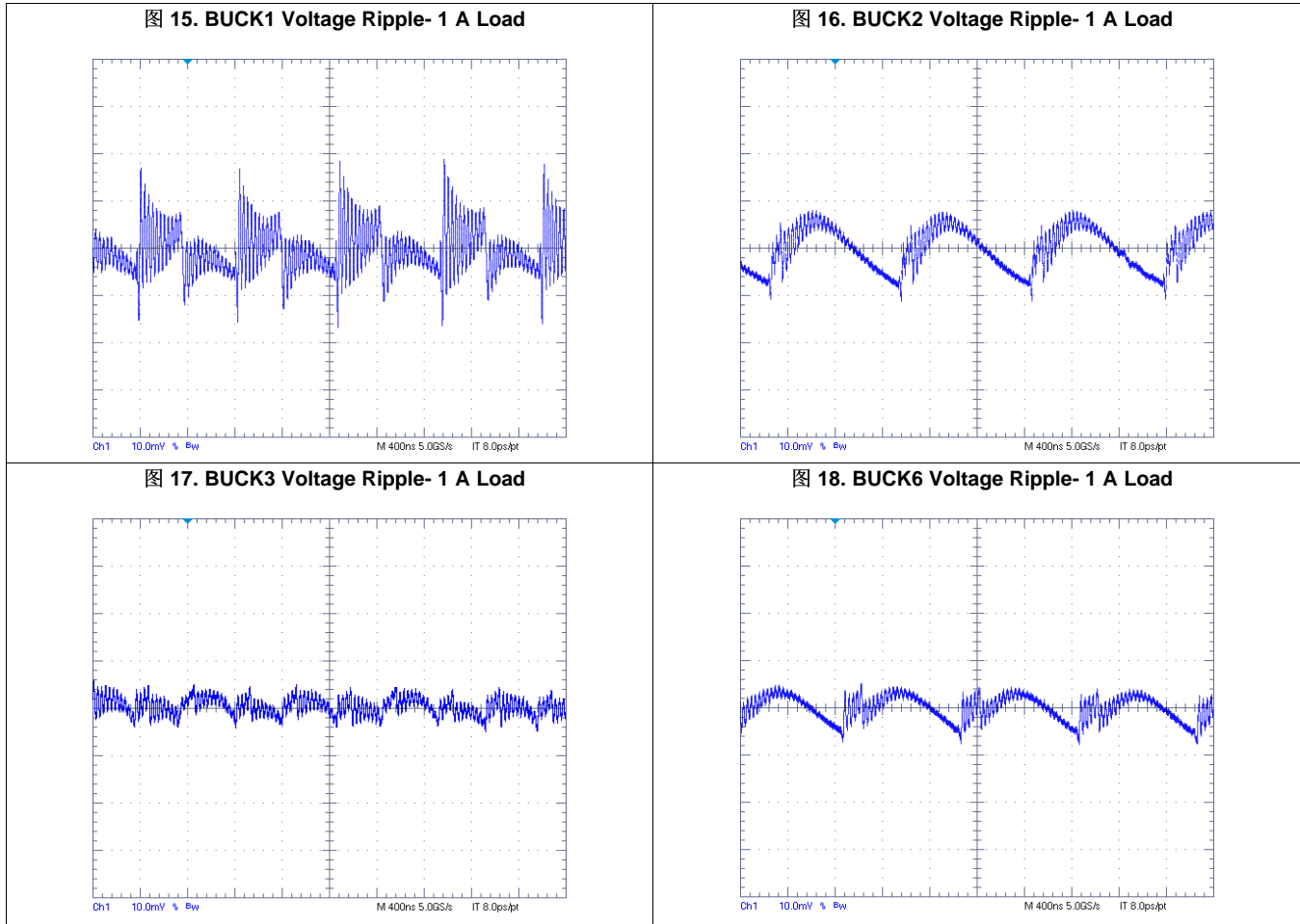
图 19. BUCK2 Transient 1 A to 3 A

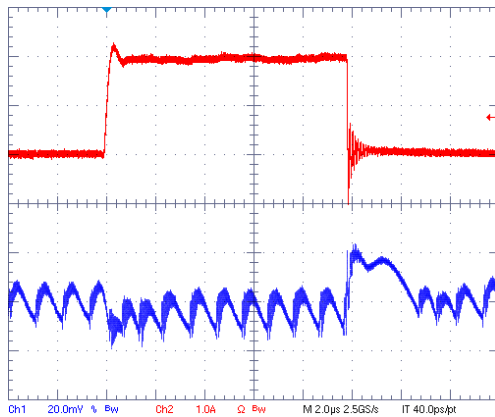

Transient that would be expected on BUCK2 if it were powering the VCC\_PSINTLP rail on the ZU3EG.

图 20. BUCK3 Transient 1 A to 1.5 A

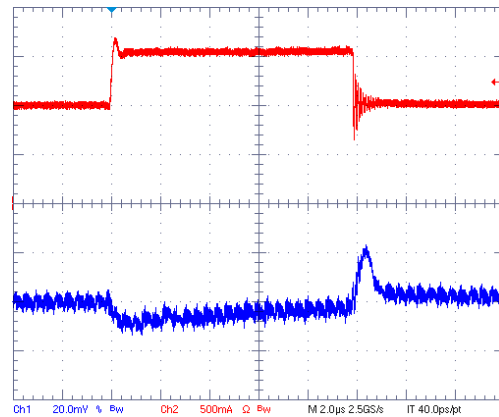

Transient that would be expected on BUCK3 if it were powering the VCCO\_PSDDR rail on the ZU3EG.

图 21. BUCK6 Transient 1 A to 1.2 A

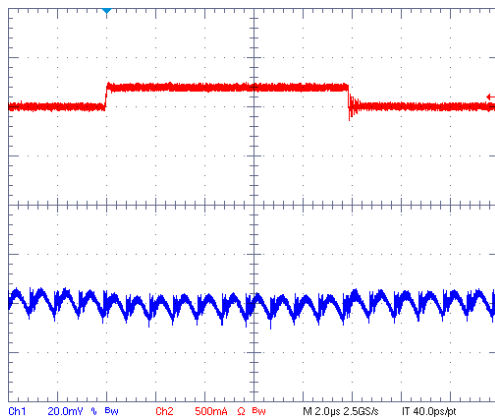

Transient that would be expected on BUCK6 if it were powering the VCCAUX rail on the ZU3EG.

图 22. VTT\_LDO Transient 150 mA to 300 mA

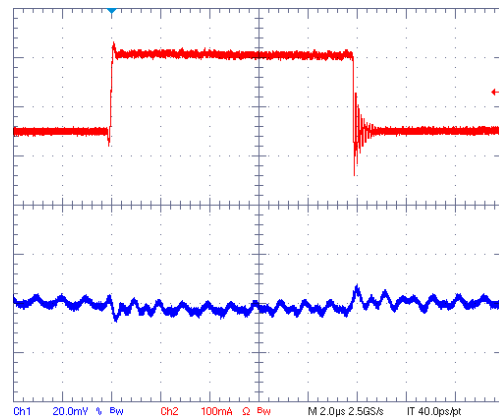

Transient that would be expected on VTT\_LDO if it were powering the MGTRAVCC rail on the ZU3EG.

图 23. LDOA1 Transient 25 mA to 50 mA

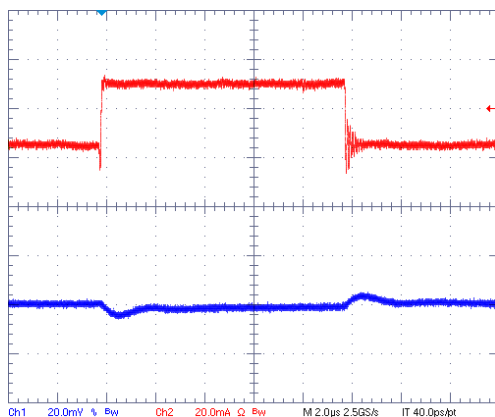

Transient that would be expected on LDOA1 if it were powering the MGTRAVTT rail on the ZU3EG.

图 24. External Load Switch (TPS22920) Transient 1 A to 3 A

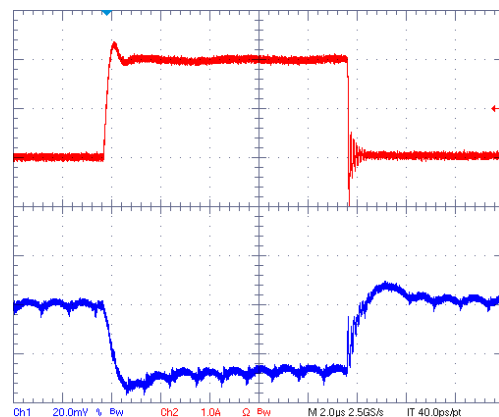

Transient that would be expected on the external TPS22920 load switch (U6) if it were powering the VCC\_PSINTFP rail on the ZU3EG.

表 6. Summary of Transient Test Results

Regulator	Step Size	Inductance	Capacitance	Overshoot	Undershoot
BUCK2	1 A to 3 A	470 nH (PN: 744383360047)	22 $\mu$ F (PN: GRM187R61A226ME15D) + 2 x 47 $\mu$ F (PN: GRM21BR61A476ME15L)	24.6 mV	-20 mV
BUCK3	1 A to 1.5 A	470 nH (PN: 74479262147)	22 $\mu$ F (PN: GRM187R61A226ME15D)	20.6 mV	-14.4 mV
BUCK6	1 A to 1.2 A	1 $\mu$ H (PN: 74479275210)	22 $\mu$ F (PN: GRM187R61A226ME15D) + 2 x 47 $\mu$ F (PN: GRM21BR61A476ME15L)	6.2 mV	-9.6 mV
VTT_LDO	150 mA to 300 mA	-	4.7 $\mu$ F (PN: C1005X5R0J475M050BC)	8.2 mV	-9.6 mV
LDOA1	25 mA to 50 mA	-	4.7 $\mu$ F (PN: C1005X5R0J475M050BC)	6.7 mV	-8 mV
External Load Switch	1 A to 3 A	-	22 $\mu$ F (PN: GRM188R61A226ME15D)	22.5 mV	-40 mV

### 3.2.2.3 Efficiency

Efficiency measurements are taken on a system level, meaning system voltage, push button circuitry, external load switches, and pre-regulators are all included in the efficiency measurements. Regulators that aren't being tested are disabled for these measurements.

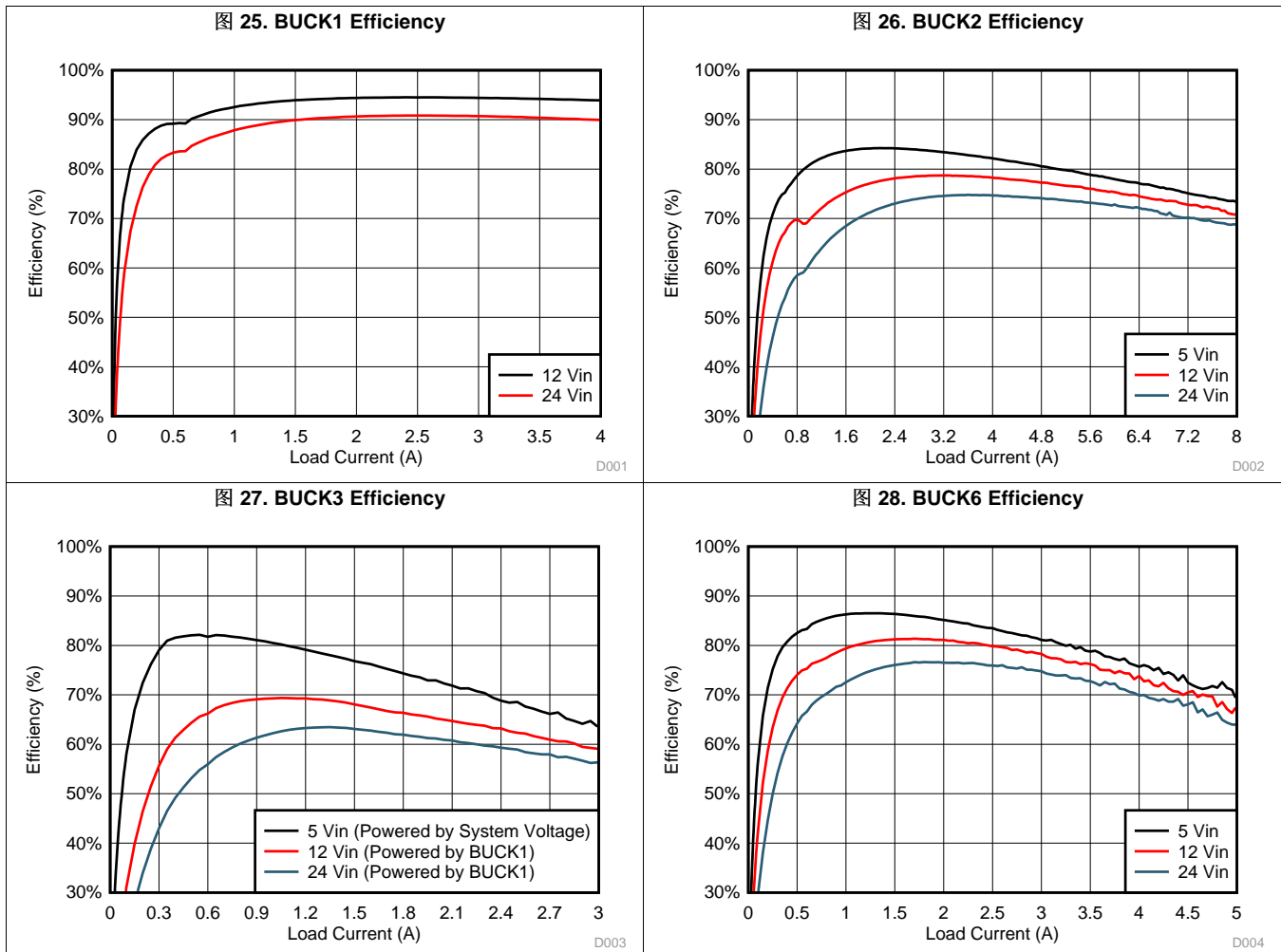

### 3.2.2.4 Sequencing and Control

The tests in this section show the functionality of the PMIC sequencing and some of the other external components.

图 29 shows how a short key press will set the CTL1 pin high, enabling the PMIC. 图 30 shows how a long key press will set the CTL1 pin low, disabling the PMIC.

图 29. Push-Button Enable



图 30. Push-Button Disable



图 31 shows how one of the external load switches can be enabled using a GPO output.

图 31. External Load Switch Functionality

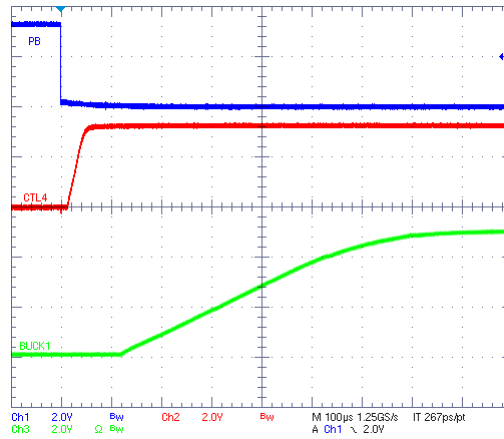

图 32 demonstrates the sequencing capabilities of the PMIC.

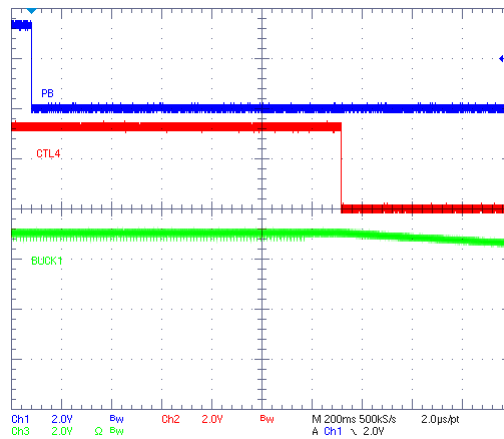
图 32. PMIC Sequencing



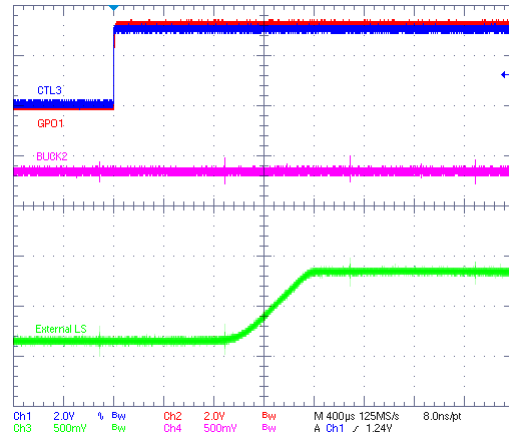
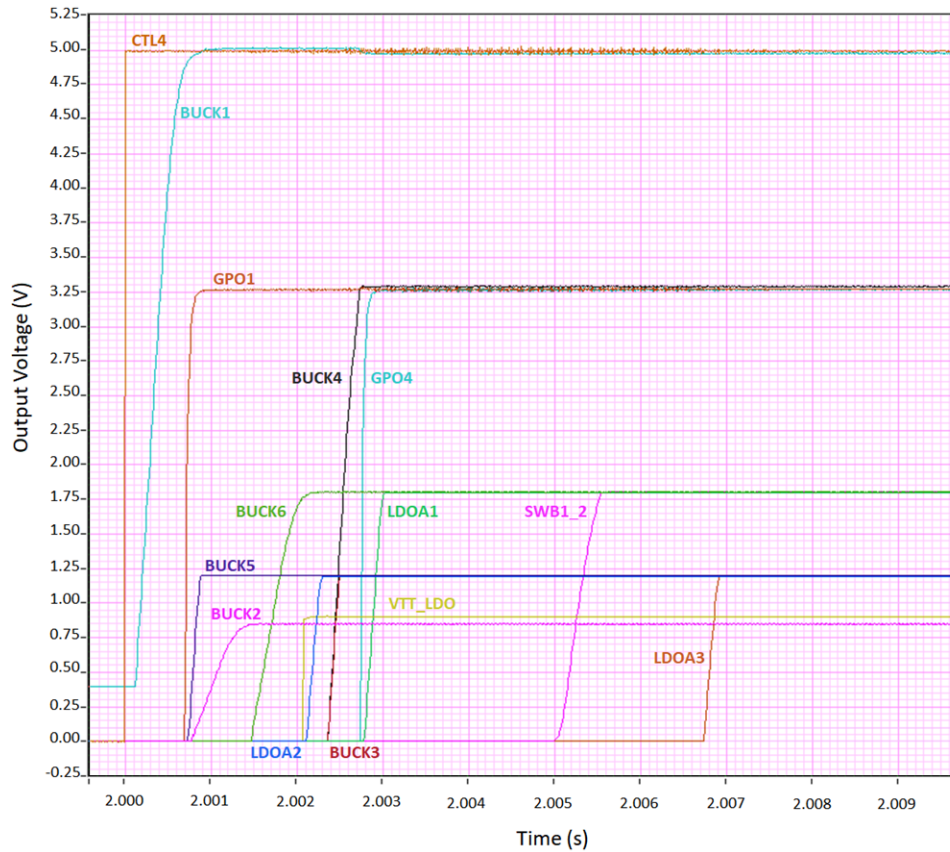

## 4 Design Files

### 4.1 Schematics

To download the schematics, see the design files at [TIDA-01393](#).

### 4.2 Bill of Materials

To download the bill of materials (BOM), see the design files at [TIDA-01393](#).

### 4.3 PCB Layout Recommendations

The layout guidelines in each device's data sheet should be used as a starting point for placement of critical components for each device.

This reference design is a 6 layer PCB with 1-oz. copper thickness and a total thickness of 62 mils. The top (first) and bottom (sixth) layers are used for component placement and for routing signals and power. The second and fifth layers are solid copper GND planes, with only a handful of traces when needed. The innermost layers (third and fourth) are reserved for routing low-speed digital signals and low-current power traces, such as the LDOs.

When doing layout for BUCK converters it is important to make sure the input capacitors are located close to the input pins, and have a strong connection to ground. The same is true for PMIC system power and to a lesser extent the LDO inputs. It is also very important that BUCK converters have output capacitors with a strong connection to ground, and that the switch nodes of the BUCK regulators have short wide traces. It is also important for the TPS65086x device to have a short, strong connection from the VREF capacitor to the AGND pin, and that the AGND pin only connects to the ground plane through a single via. The AGND pin should not connect directly to the power pad of the PMIC.

For more help on PCB layout please refer to the TPS65086x Schematic and Layout Checklist in the [TPS65086 technical documents](#)

#### 4.3.1 Layout Prints

To download the layer plots, see the design files at [TIDA-01393](#).

### 4.4 Altium Project

To download the Altium Designer® project files, see the design files at [TIDA-01393](#).

### 4.5 Gerber Files

To download the Gerber files, see the design files at [TIDA-01393](#).

### 4.6 Assembly Drawings

To download the assembly drawings, see the design files at [TIDA-01393](#).

## 5 Software Files

To download the software files, see the design files at [TIDA-01393](#).

## 6 Related Documentation

1. Texas Instruments, [TPS65086x Evaluation Module User's Guide](#)

2. Texas Instruments, [BOOSTXL-TPS650861 EVM User's Guide](#)
3. Texas Instruments, [Push-Button Circuit app note](#)
4. Texas Instruments, [TPS22920EVM-002 User's Guide](#)
5. Texas Instruments, [AN-2183 LMR62014/LMR64010 Demo Board](#)
6. Texas Instruments, [TPS54308EVM-876 3-A Regulator Evaluation Module](#)
7. Xilinx, [AES-ULTRA96-G](#)

## 6.1 商标

E2E is a trademark of Texas Instruments.

Altium Designer is a registered trademark of Altium LLC or its affiliated companies.

All other trademarks are the property of their respective owners.

## 6.2 Third-Party Products Disclaimer

TI'S PUBLICATION OF INFORMATION REGARDING THIRD-PARTY PRODUCTS OR SERVICES DOES NOT CONSTITUTE AN ENDORSEMENT REGARDING THE SUITABILITY OF SUCH PRODUCTS OR SERVICES OR A WARRANTY, REPRESENTATION OR ENDORSEMENT OF SUCH PRODUCTS OR SERVICES, EITHER ALONE OR IN COMBINATION WITH ANY TI PRODUCT OR SERVICE.

## 修订历史记录

注：之前版本的页码可能与当前版本有所不同。

Changes from Original (June 2019) to A Revision	Page
• 已更改 将 ZUS9DR 更改为 ZU21DR，因为本设计不包含附加的射频轨 .....	1
• 已添加 note explaining additional power requirements for RFSocS.....	9

## 重要声明和免责声明

TI 均以“原样”提供技术性 & 可靠性数据（包括数据表）、设计资源（包括参考设计）、应用或其他设计建议、网络工具、安全信息和其他资源，不保证其中不含任何瑕疵，且不做任何明示或暗示的担保，包括但不限于对适销性、适合某特定用途或不侵犯任何第三方知识产权的暗示担保。

所述资源可供专业开发人员应用 TI 产品进行设计使用。您将对以下行为独自承担全部责任：(1) 针对您的应用选择合适的 TI 产品；(2) 设计、验证并测试您的应用；(3) 确保您的应用满足相应标准以及任何其他安全、安保或其他要求。所述资源如有变更，恕不另行通知。TI 对您使用所述资源的授权仅限于开发资源所涉及 TI 产品的相关应用。除此之外不得复制或展示所述资源，也不提供其它 TI 或任何第三方的知识产权授权许可。如因使用所述资源而产生任何索赔、赔偿、成本、损失及债务等，TI 对此概不负责，并且您须赔偿由此对 TI 及其代表造成的损害。

TI 所提供产品均受 TI 的销售条款 (<http://www.ti.com.cn/zh-cn/legal/termsofsale.html>) 以及 [ti.com.cn](http://www.ti.com.cn) 上或随附 TI 产品提供的其他可适用条款的约束。TI 提供所述资源并不扩展或以其他方式更改 TI 针对 TI 产品所发布的可适用的担保范围或担保免责声明。

邮寄地址：上海市浦东新区世纪大道 1568 号中建大厦 32 楼，邮政编码：200122  
Copyright © 2019 德州仪器半导体技术（上海）有限公司

## 重要声明和免责声明

TI 均以“原样”提供技术性数据（包括数据表）、设计资源（包括参考设计）、应用或其他设计建议、网络工具、安全信息和其他资源，不保证其中不含任何瑕疵，且不做任何明示或暗示的担保，包括但不限于对适销性、适合某特定用途或不侵犯任何第三方知识产权的暗示担保。

所述资源可供专业开发人员应用TI 产品进行设计使用。您将对以下行为独自承担全部责任：(1) 针对您的应用选择合适的TI 产品；(2) 设计、验证并测试您的应用；(3) 确保您的应用满足相应标准以及任何其他安全、安保或其他要求。所述资源如有变更，恕不另行通知。TI 对您使用所述资源的授权仅限于开发资源所涉及TI 产品的相关应用。除此之外不得复制或展示所述资源，也不提供其它TI 或任何第三方的知识产权授权许可。如因使用所述资源而产生任何索赔、赔偿、成本、损失及债务等，TI 对此概不负责，并且您须赔偿由此对TI 及其代表造成的损害。

TI 所提供产品均受TI 的销售条款 (<http://www.ti.com.cn/zh-cn/legal/termsofsale.html>) 以及ti.com.cn上或随附TI产品提供的其他可适用条款的约束。TI提供所述资源并不扩展或以其他方式更改TI 针对TI 产品所发布的可适用的担保范围或担保免责声明。

邮寄地址：上海市浦东新区世纪大道 1568 号中建大厦 32 楼，邮政编码：200122  
Copyright © 2019 德州仪器半导体技术（上海）有限公司